

STANDARD FEATURES

- All Stainless Steel Construction
- External Recalibration Adjustment
- White dial with black markings
- Accurate to ±1% of Scale Range
- Gasketed Glass Face
- Case is sealed to exclude dirt, dust and moisture
- 5" dial size

CATALOG NUMBERS*		
STEM LENGTH	90° BACK ANGLE FORM	STRAIGHT FORM
2½"	5A02	5S02
4"	5A04	5S04
6"	5A06	5S06
9"	5A09	5S09
12"	5A12	5S12
15"	5A15	5S15
18"	5A18	5S18
24"	5A24	5S24

Longer stem lengths available on special order

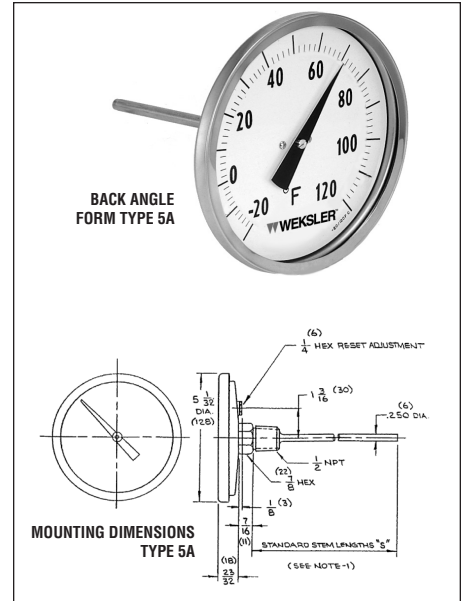

STANDARD RANGES

CODE	Fahrenheit
FC	-80 to 120°F
FE	-40 to 120°F
FG	0 to 150°F
FJ	0 to 200°F
FL	0 to 250°F
FM	30 to 240°F
FN	30 to 130°F †
FR	50 to 300°F
FS	50 to 400°F
FT	50 to 550°F
FX	150 to 750°F †
FY	200 to 1000°F* †

CODE	Celsius
CD	-50 to 50°C
CJ	0 to 100°C
CM	-10 to 110°C
CN	0 to 50°C
CR	0 to 150°C
CS	0 to 200°C
CU	0 to 300°C
CX	50 to 450°C †
CY	100 to 550°C* †

CODE	DUAL SCALE	
	Fahrenheit (on outside)	Celsius (on inside)
DE	-40/120°F	and -40/50°C
DF	40/160°F	and -40/70°C
DN	30/130°F	and 0/55°C †
DJ	-0/200°F	and -20/94°C
DL	0/250°F	and -20/120°C
DR	50/300°F	and 10/150°C
DS	50/400°F	and 10/200°C
DT	50/550°F	and 10/290°C
DX	100/800°F*	and 40/430°C †
DY	200/1,000°F	and 100/550°C* †

*Not recommended for continuous service above 800°F (425°C). For such temperatures see pg. 63.
 †Minimum stem length for these ranges 4".

CODE	DESCRIPTION
EL	Liquid Filling for Catalog No's AF, 3A, 5A only
PD	Plastic Window
SG	Shatter Proof Glass
NN	Paper Tag
NH	Stainless Steel Tag
DM	Dial Markings
C4	Calibration Certificate

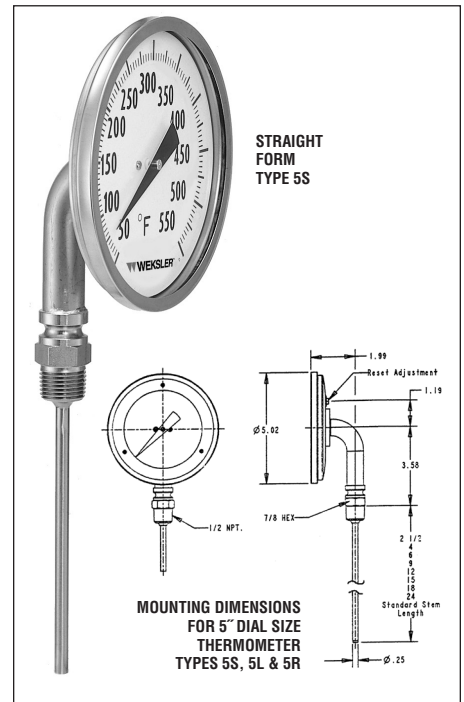

**SEPARABLE THERMOWELLS AVAILABLE
SEE PAGES 59 - 63**

HOW TO ORDER

5 A 0 6 4 4 F J X

1. Basic 4-digit Catalog No. From Table Above _____
2. Stem Diameter: "4" = .250" O.D. (Standard); "5" = .375" O.D. (Extra Cost) _____
3. Thread Size: "4" = ½ NPT Male; 2 = ¼ NPT Male, Back Angle Rear Only (Extra Cost) _____
4. 2 Digit Range Code from Range Tables Above _____
5. Option(s): "X" = Non Required Option(s) Required (Extra Cost) Select code from above table _____